

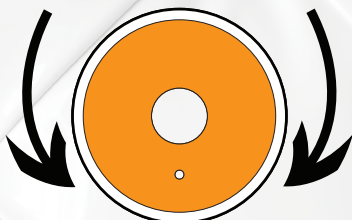

3-PHASES

AVAILABLE IN 480 V

AVAILABLE IN 60 Hz



BI-DIRECTIONAL



1946

GRT12DT

ELECTRIC 3-PHASES BIDIRECTIONAL CUTTING UNIT

GRT12DT. Professional cutting unit for bidirectional cross-cut processes in Textile & Technical Textile applications.



ELECTRIC 3-PHASE BIDIRECTIONAL CUTTING UNIT GRT12DT

WHAT'S NEW:

- Save time with bi-directional cutting system
- Low-friction Teflon coated foot
- Easy fixing structure for O.E.M. applications
- Maintenance-free industrial motor

AVAILABLE IN 480 V
AVAILABLE IN 60 Hz

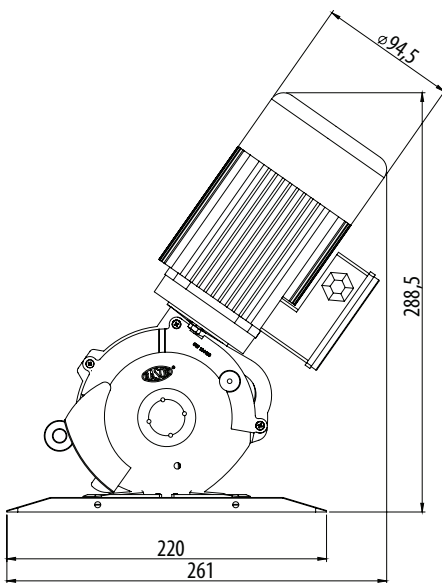
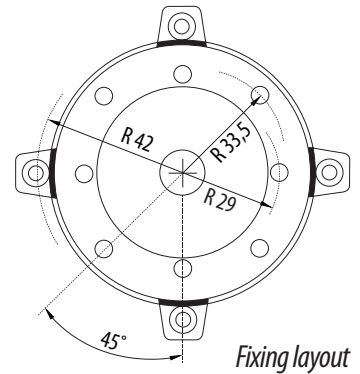

Dimension layout

TECHNICAL DETAILS:

- Blade diameter:** 120 mm (4.7"), with hard metal counterblade
- Blade equipped:** 12SHSS, 8-edges, HSS steel
- Blade speed:** 400 r.p.m.
- Cutting ability:** up to 50 mm (2") bidirectional
- Motor:** 3-phase asynchronous 380/400 V, 50 Hz
- Power:** 180 W
- Max. absorption:** 0.52 A
- Protection:** IP20 - CL F
- Net weight:** 4590 g (with power supply cord)
- Total weight (with packing box):** 6290 g
- Electric cable length:** 1.5 mt (with no plug)
- Minimum brightness for working operations:** LUX 200
- Vibrations at start up:** < 2.5 m/sec 2
- Temperature range:** 0 – 55 C
- Umidity range:** 10 – 95% without condensate

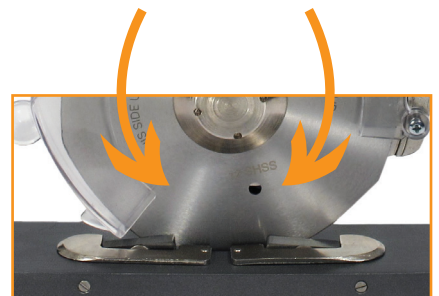

bidirectional cutting system

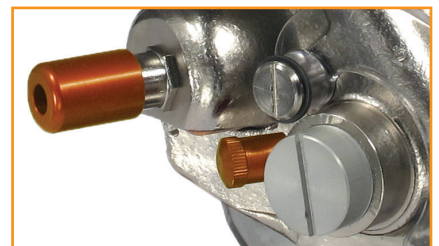

sharpening device

BLADES AVAILABLE:

12SHSS, 120 mm 8-edges, HSS steel | **12CHSS**, 120 mm circular, HSS steel | **12DHSS**, 120 mm 12-edges, HSS steel | **12SHSSTF**, 120 mm 8-edges, HSS steel Teflon® coated | **12SHSSTN**, 120 mm 8-edges, HSS steel Titanium coated | **12DHSSTN**, 120 mm 12-edges, HSS steel Titanium coated | **12SMD**, 120 mm 8-edges, Carbide (Widia®)



PETRONI SRL
Via A.Bucchi, 1/B
06012 Città di Castello (PG)
+39 075/852.07.87
www.petronisrl.it